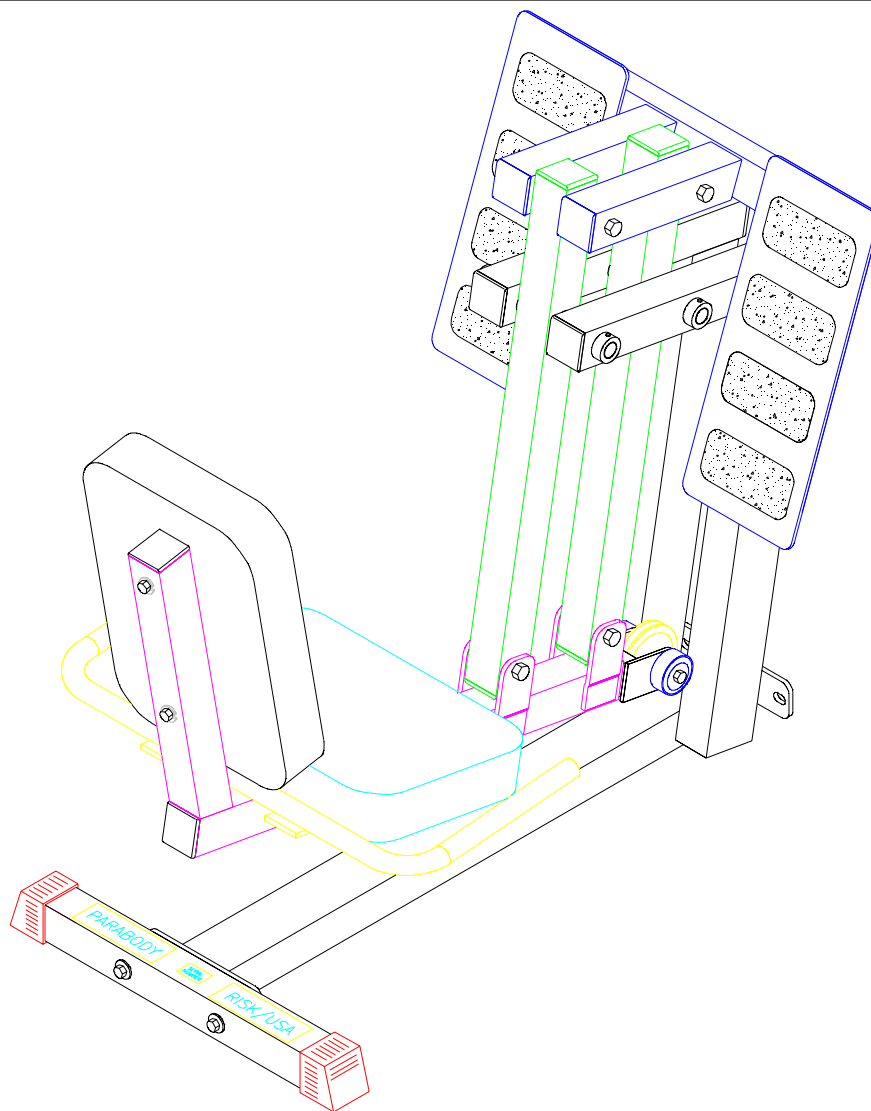


# PARABODY

*Serious Steel*

832102 LEG PRESS

---



## ASSEMBLY INSTRUCTIONS

## IMPORTANT NOTES

WELCOME TO THE WORLD OF  **Serious steel!**

**Please note:**

\* Thank you for purchasing the Parabody 832102 LEG PRESS. Please read these instructions thoroughly and keep them for future reference. This product must be assembled on a flat, level surface to assure its proper function.

We recommend cleaning your product (pads and frame) on a regular basis, using warm soapy water. Touch-up paint can be purchased from your Parabody customer service representative at (800) 328-9714.

There is a risk assumed by individuals who use this type of equipment. To minimize risk, please follow these rules:

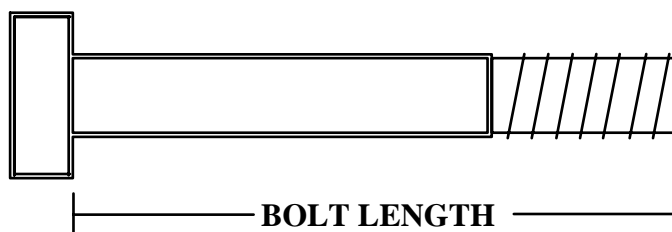
1. Inspect equipment daily. Tighten all loose connections and replace worn parts immediately. Failure to do so may result in serious injury.
2. Do not allow minors or children to play on or around this equipment.
3. Exercise with care to avoid injury.
4. If unsure of proper use of equipment, call your local Parabody distributor or call the Parabody customer service department at (800) 328-9714.
5. Consult a physician before beginning any exercise program.

### Tools Required for Assembly

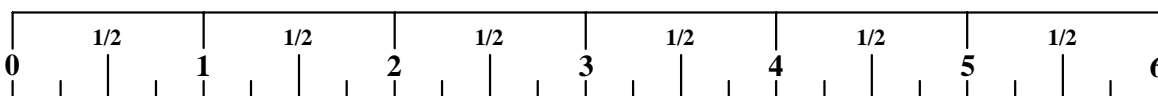
- \* 3/4" wrench
- \* 9/16" wrench
- \* Ratchet with 3/4" and 9/16" sockets
- \* Adjustable wrench
- \* 5/32" Allen wrench
- \* Tape measure

### Bolt Length Ruler

**NOTE: BOLT LENGTH IS MEASURED FROM THE UNDERSIDE OF THE HEAD OF THE BOLT.**



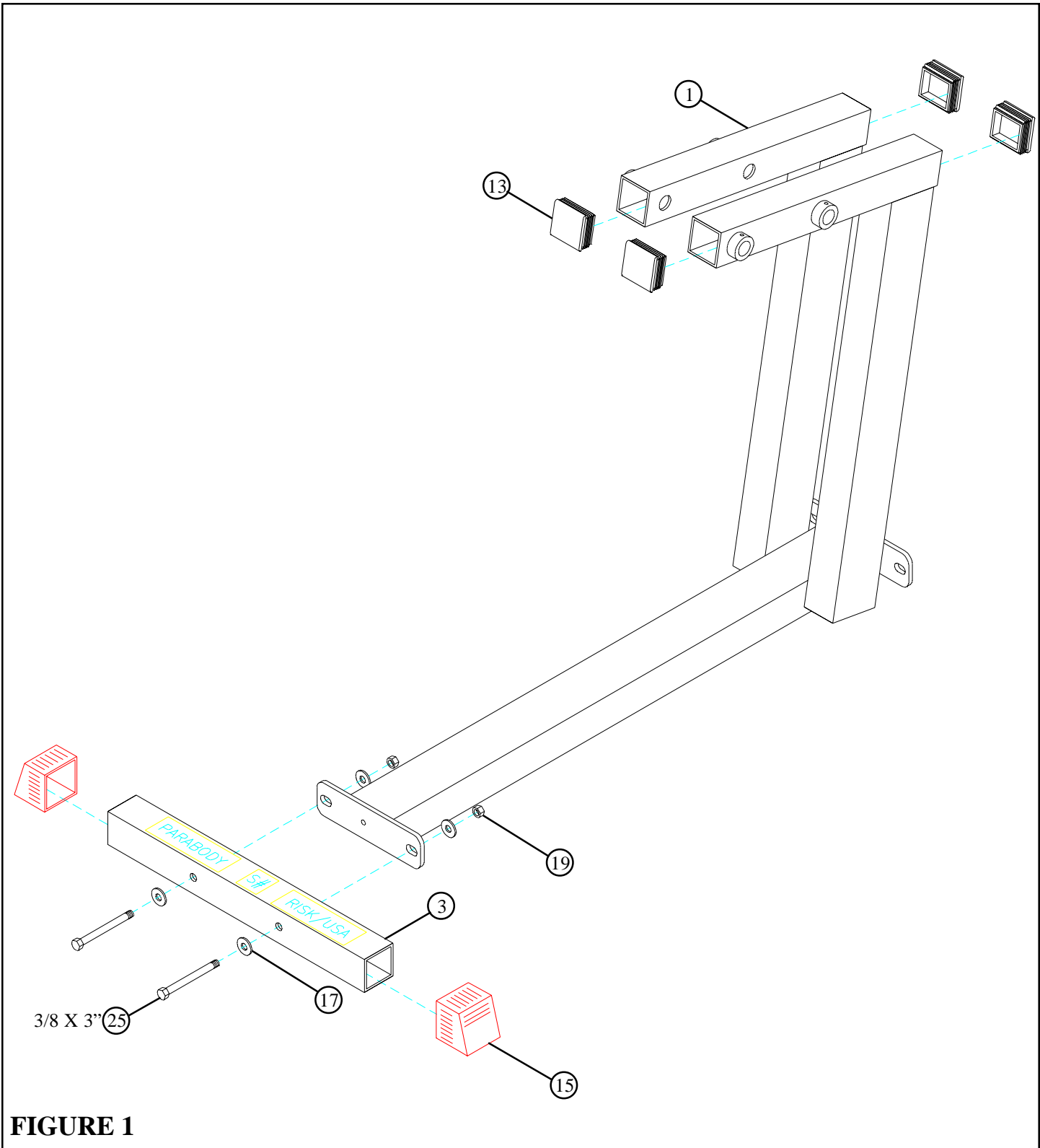
**BOLT LENGTH RULER:**



# PARTS LIST

KEY	PART #	DESCRIPTION	QTY
1	6574503	BASE FRAME	1
2	6573603	SEAT FRAME	1
3	6655701	REAR TUBE	1
4	6575403	FOOT PLATE	1
5	6573903	LEVER TUBE	2
6	6476403	HANDLE	1
7	6575102	ADJUSTMENT TUBE	1
8	6597402	SEAT PAD	2
9	6574001	3/4 X 8-1/4" SHAFT	2
10	3103102	1 X 8" GRIP	2
11	3116201	3-1/2" PULLEY	1
12	6177001	2-1/2 X 5-1/2" NON-SKID STRIP	8
13	6405201	2" SQ. END CAP	14
14	6416601	PARAGLIDE (QTY. 8)	1
15	6467001	2" SQ. COVER CAP	2
16	6500601	2" WHEEL	2
17	3102501	3/8" FLAT WASHER	8

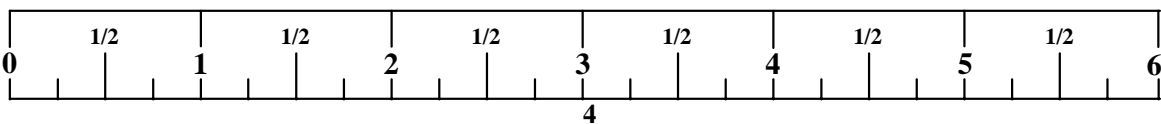
KEY	PART #	DESCRIPTION	QTY
18	3102601	3/8" LOCK WASHER	4
19	3102802	3/8" LOCK NUT	2
20	3102807	3/8" LOW HEIGHT LOCK NUT	1
21	3102801	1/2" LOCK NUT	2
22	3102804	1/2" LOW HEIGHT LOCK NUT	2
23	3102941	3/8 X 1-1/2" BOLT	2
24	3102922	3/8 X 2-3/4" BOLT	2
25	3102904	3/8 X 3" BOLT	2
26	3102935	3/8 X 4-1/2" BOLT	1
27	3102918	1/2 X 3-1/4" BOLT	2
28	3202107	1/2 X 6-1/2" BOLT	2
29	6122703	3/8 ID X 3/8" SPACER	2
30	6020601	1/2" FLANGE BEARING	8
31	3104901	3/4" FLANGE BEARING	4
32	3106803	5/16" SET SCREW	4
33	6412001	3/8" SPRING PIN	1

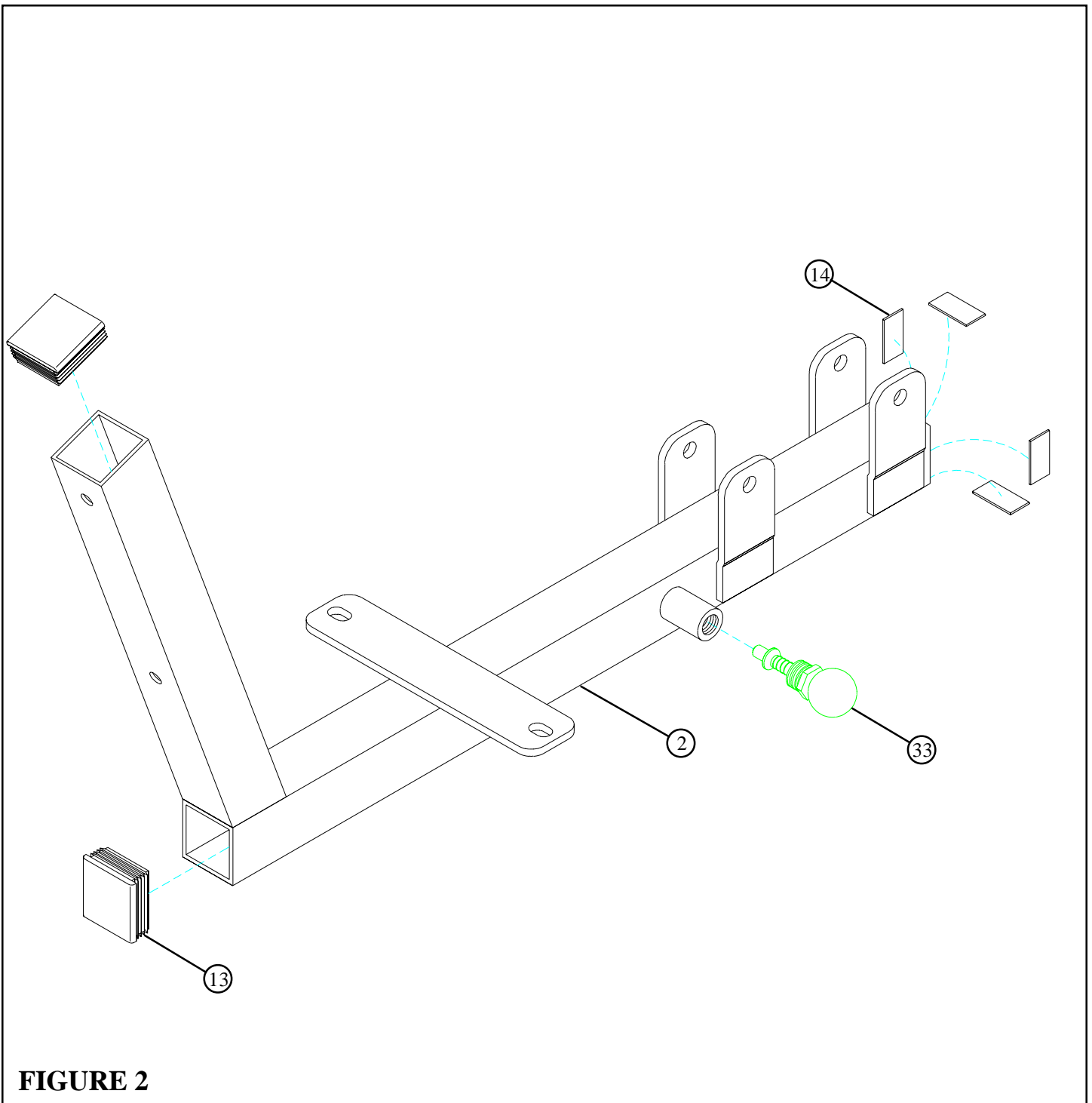


**FIGURE 1**

**STEP 1:**

- Attach two 2" SQ. COVER CAPS (15) onto the ends of the REAR TUBE (3) as shown in FIGURE 1.
- Insert four 2" SQ. ENDCAPS (13) into the ends of the BASE FRAME (1) as shown in FIGURE 1.
- **SECURELY** assemble the REAR TUBE (3) to the BASE FRAME (1) using two 3/8 X 3" BOLTS (25), four 3/8" FLAT WASHERS (17), and two 3/8" LOCK NUTS (19). See FIGURE 1.

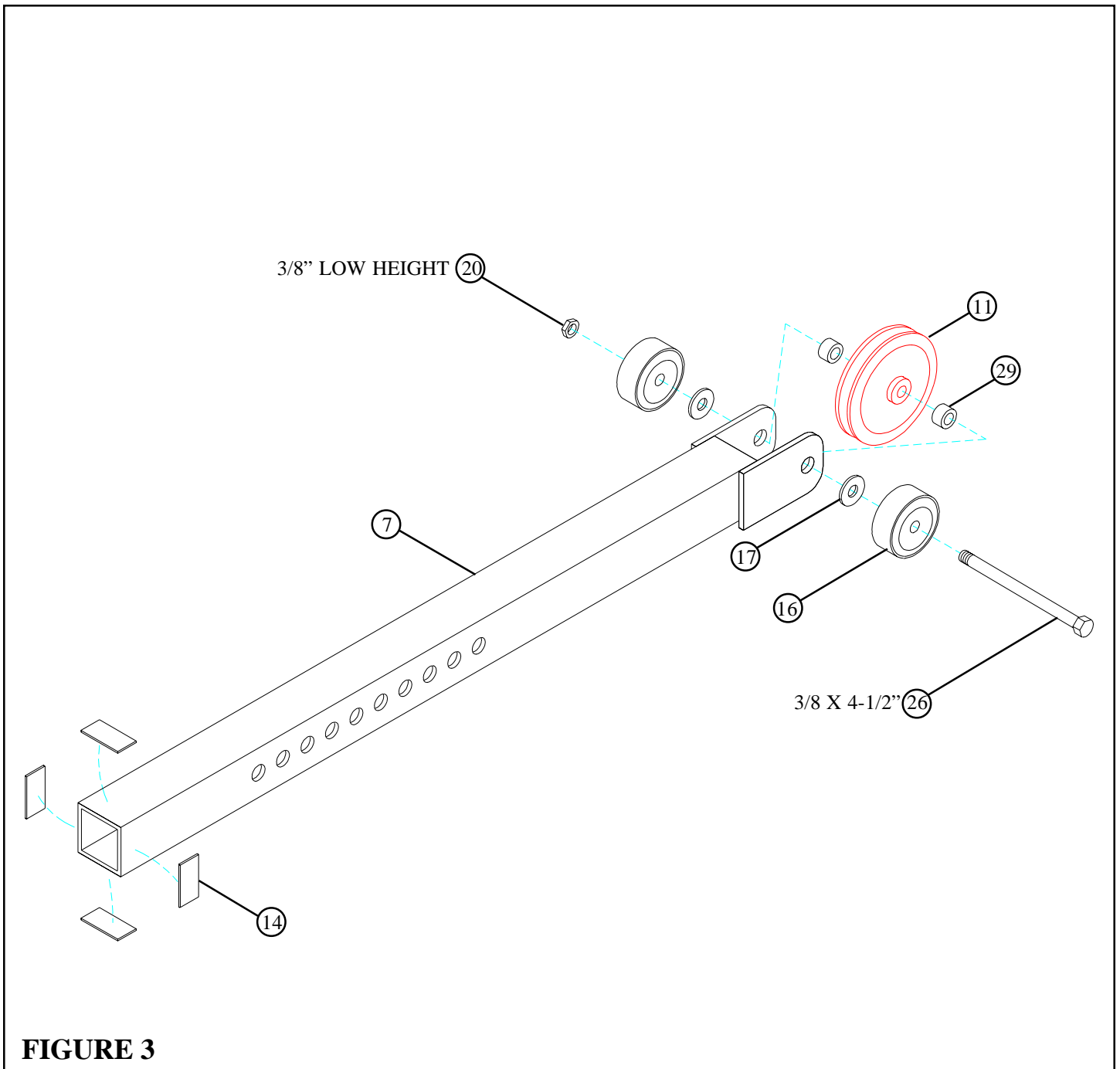




**FIGURE 2**

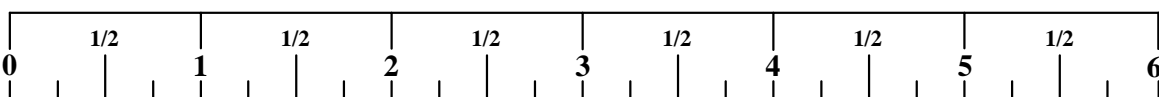
**STEP 2:**

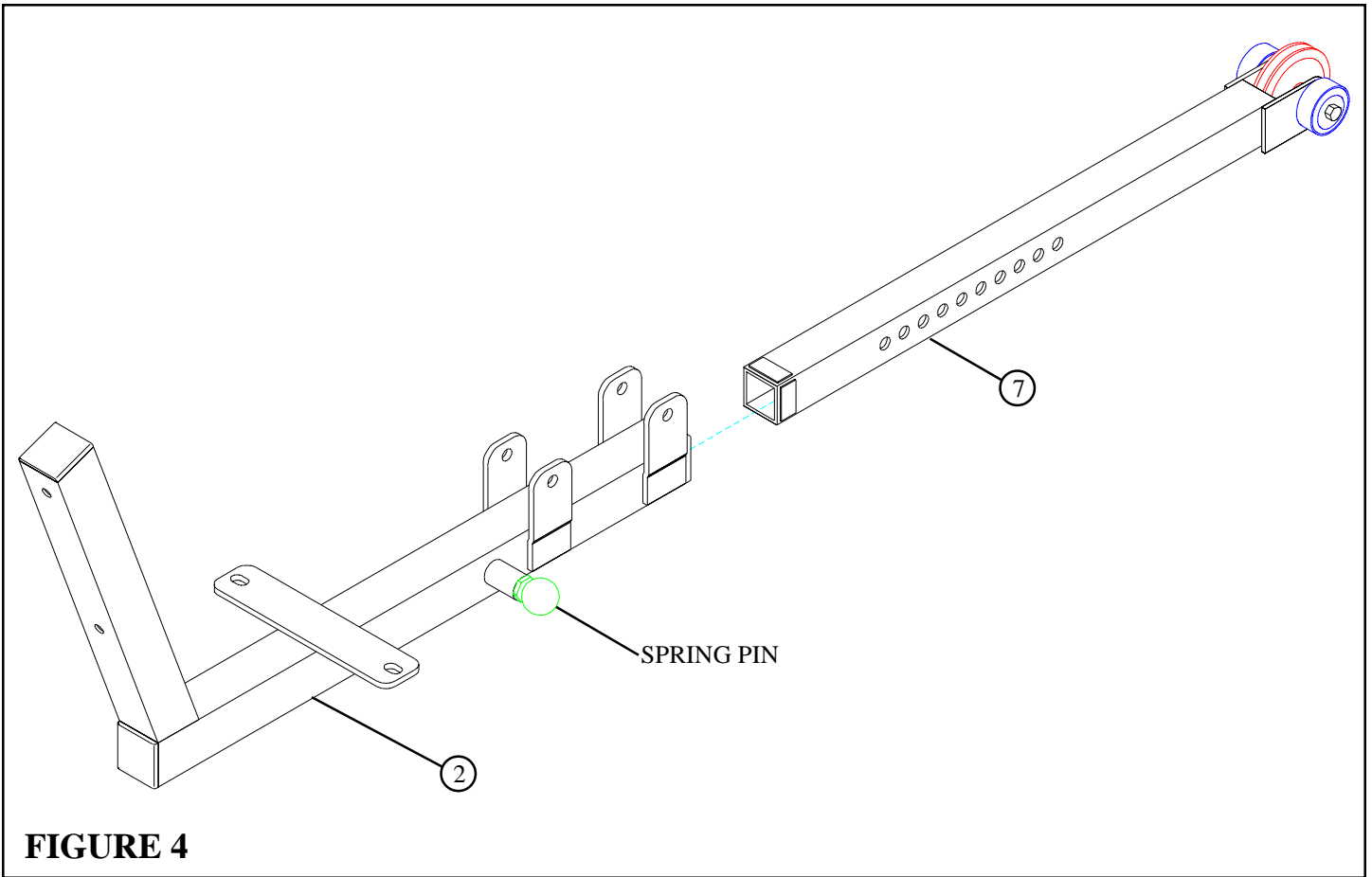
- Insert two 2” SQ. ENDCAPS (13) into the ends of the SEAT FRAME (2) as shown in FIGURE 2.
- **SECURELY** assemble one 3/8” SPRING PIN (33) to the spring pin barrel on the SEAT FRAME (2) as shown in FIGURE 2.
- Attach four PARAGLIDE STRIPS (14) to the *inside* of the SEAT FRAME (2) using the following steps:
  - Thoroughly clean all surfaces where the PARAGLIDE STRIPS (14) are to be attached.
  - Remove the PARAGLIDE STRIPS (14) from the paper backing and firmly apply them to all shown surfaces.



**STEP 3:**

- **SECURELY** assemble one 3-1/2" PULLEY (11), two 2" WHEELS (16), two 3/8" FLAT WASHERS (17), and two 3/8 ID X 3/8" SPACERS (29) to the ADJUSTMENT TUBE (7) using one 3/8 X 4-1/2" BOLT (26) and one LOW HEIGHT LOCK NUT (20) as shown in FIGURE 3.
- Attach four PARAGLIDE STRIPS (14) to the *outside* of the ADJUSTMENT TUBE (7) using the following steps:
  - Thoroughly clean all surfaces where the PARAGLIDE STRIPS (14) are to be attached.
  - Remove the PARAGLIDE STRIPS (14) from the paper backing and firmly apply them to all shown surfaces.

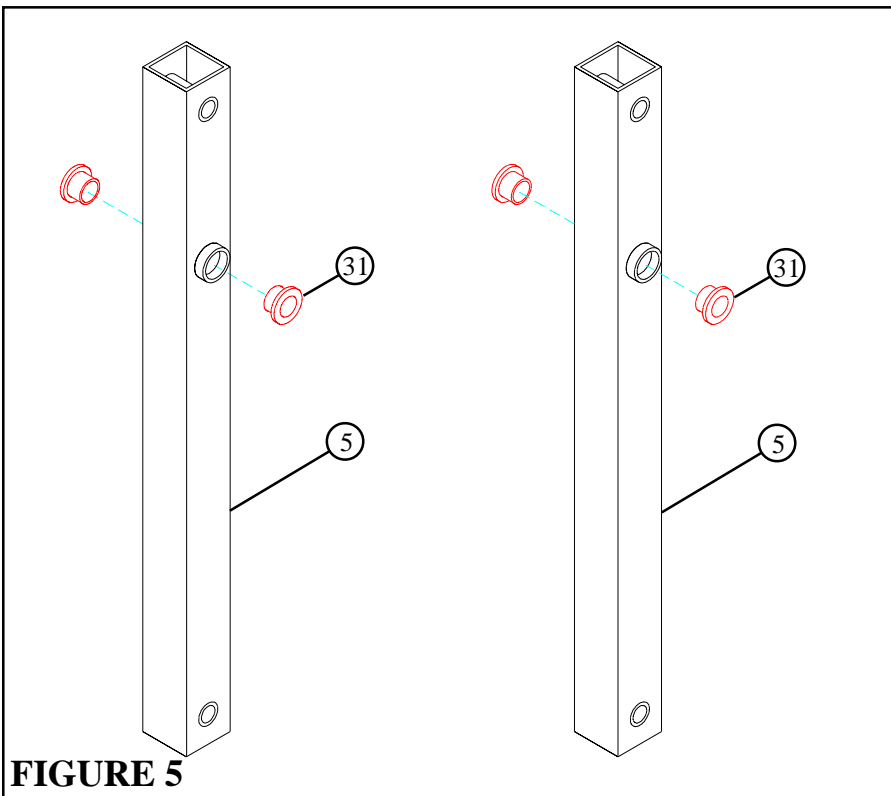




**FIGURE 4**

**STEP 4:**

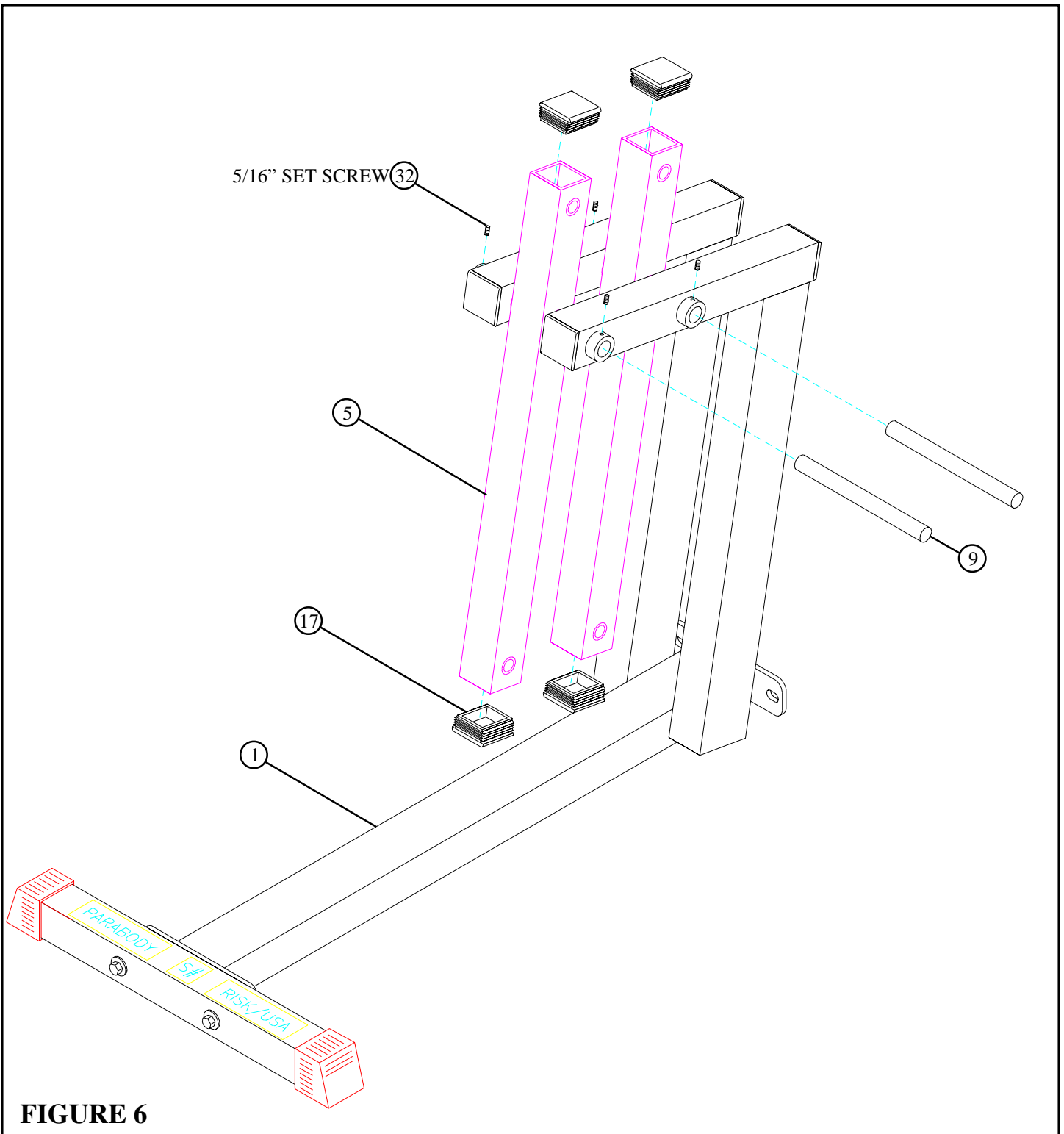
- **CAREFULLY** slide the ADJUSTMENT TUBE (7) over into the SEAT FRAME (2) and engage the SPRING PIN into one of the adjustment holes. See FIGURE 4.



**STEP 5:**

- Insert two 3/4" FLANGE BEARINGS (31) into each of the two LEVER TUBES (5) as shown in FIGURE 5.

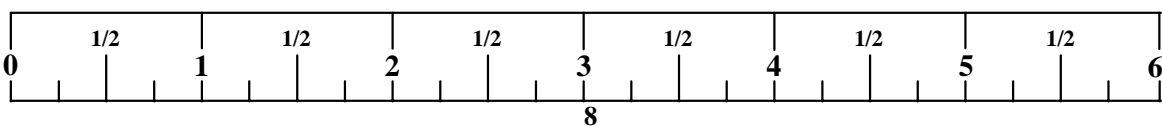
**FIGURE 5**



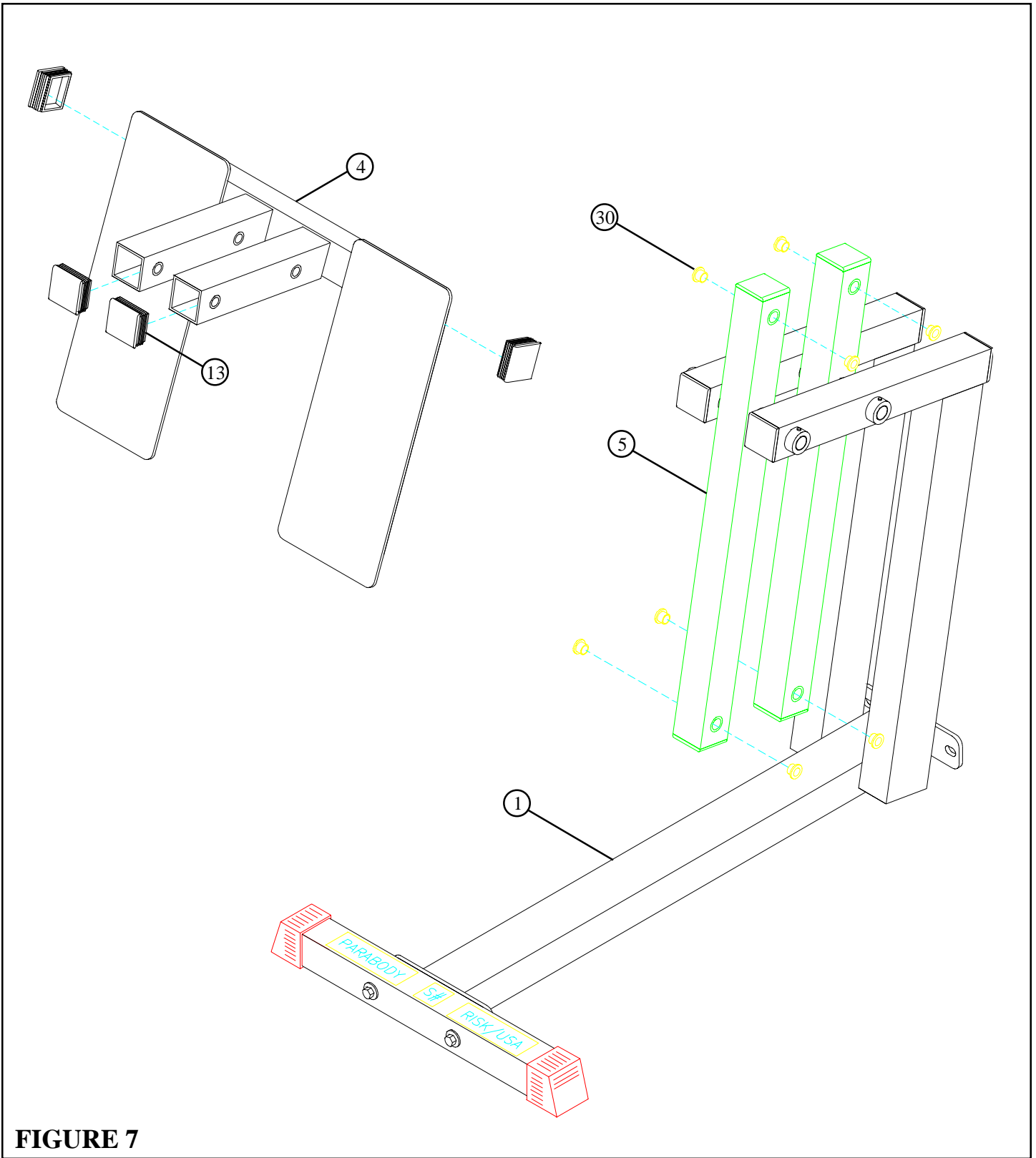
**FIGURE 6**

**STEP 6:**

- Insert four 2" SQ. END CAPS (13) into the ends of two LEVER TUBES (5) as shown in FIGURE 6.
- **SECURELY** assemble the LEVER TUBES (5) to the BASE FRAME (1) using two 3/4" SHAFTS (9) and **SECURE** in place using four 5/16" SET SCREWS (32). See FIGURE 6.



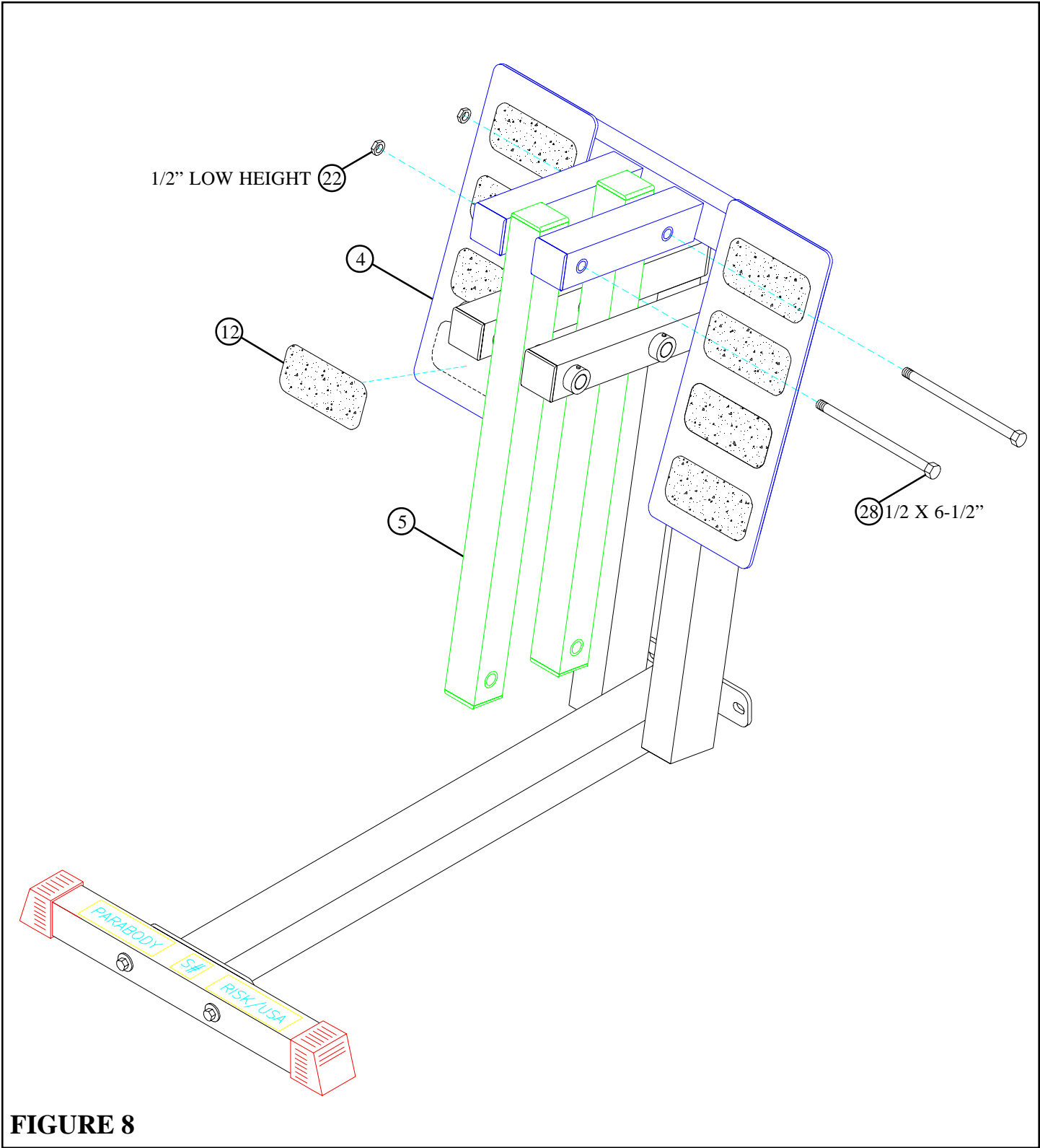




**FIGURE 7**

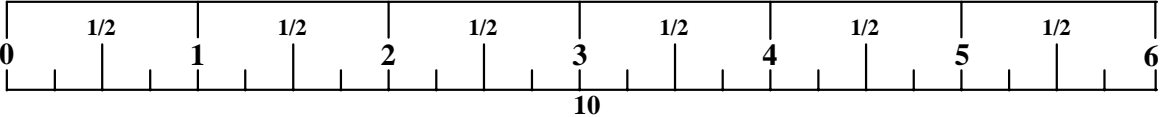
**STEP 7:**

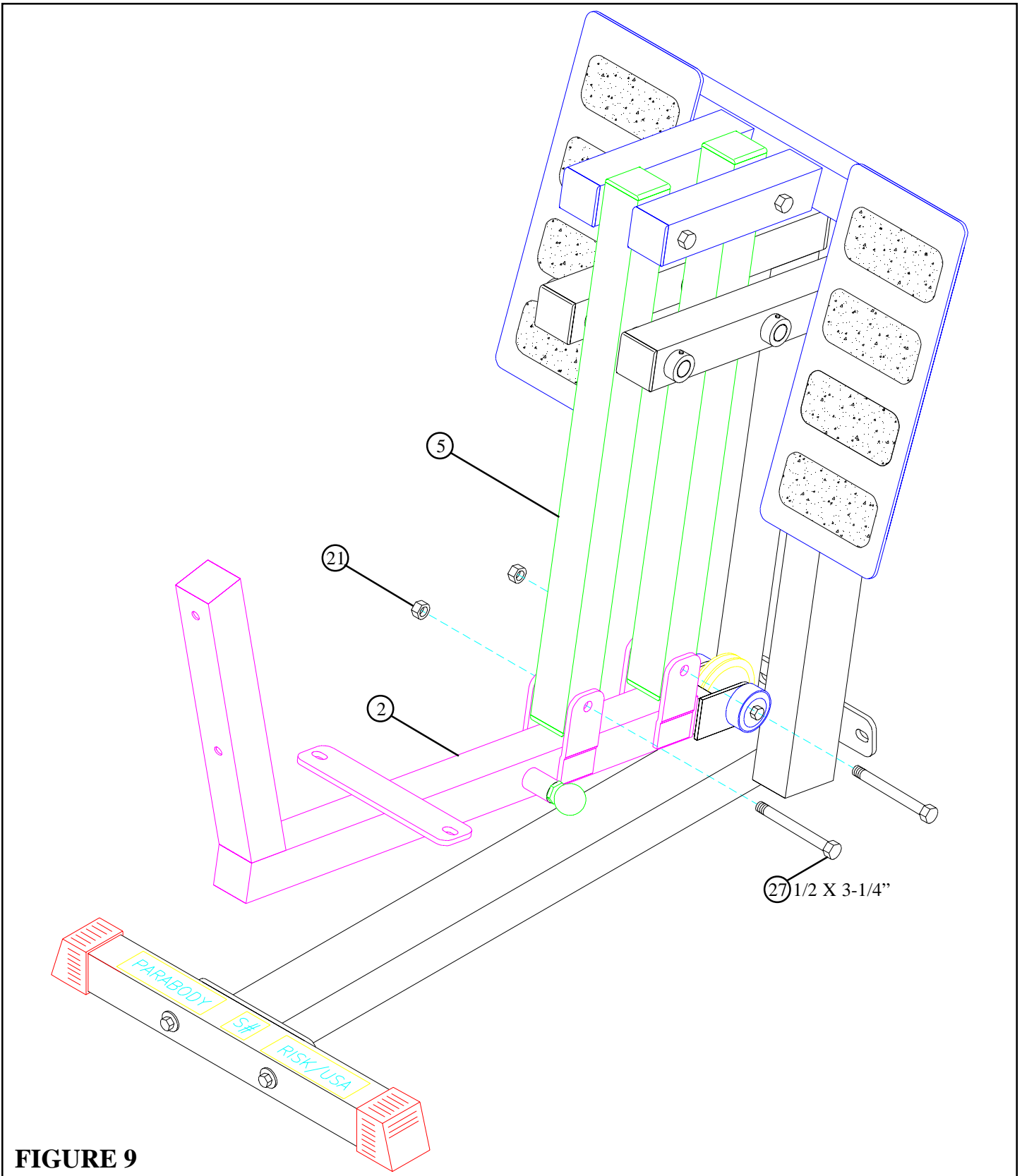
- Insert four 2" SQ. END CAPS (13) into the ends of FOOT PLATE (4) as shown in FIGURE 7.
- Insert eight 1/2" FLANGE BEARING (30) into the LEVER TUBES (5) as shown in FIGURE 7.



**STEP 8:**

- **SECURELY** assemble the FOOT PLATE (4) to the LEVER TUBES (5) using two 1/2 X 6-1/2” BOLTS (28) and two 1/2” LOW HEIGHT LOCK NUTS (22) as shown in FIGURE 8.
- **CAREFULLY** attach eight NON-SKID STRIPS (12) to the FOOT PLATE (4) as shown in FIGURE 8.

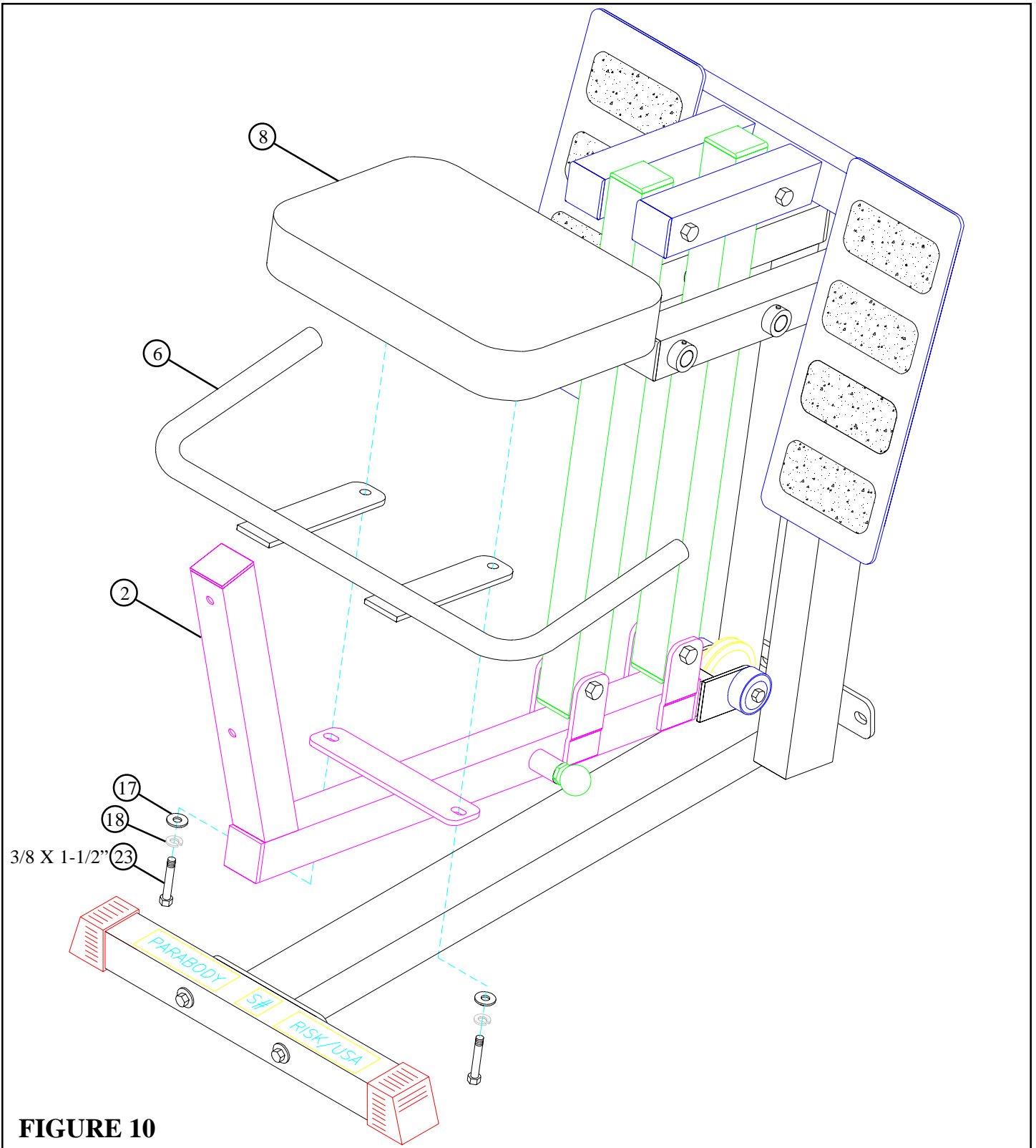




**FIGURE 9**

**STEP 9:**

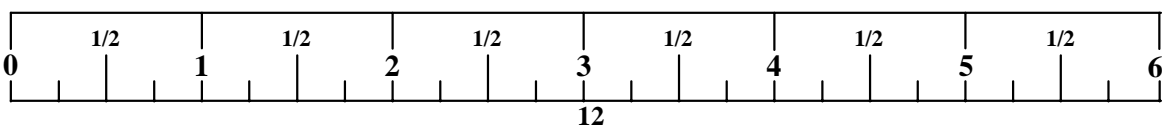
- **SECURELY** assemble the SEAT FRAME (2) to the LEVER TUBES (5) using two 1/2 X 3-1/4" BOLTS (27) and two 1/2" LOCK NUTS (21) as shown in FIGURE 9.

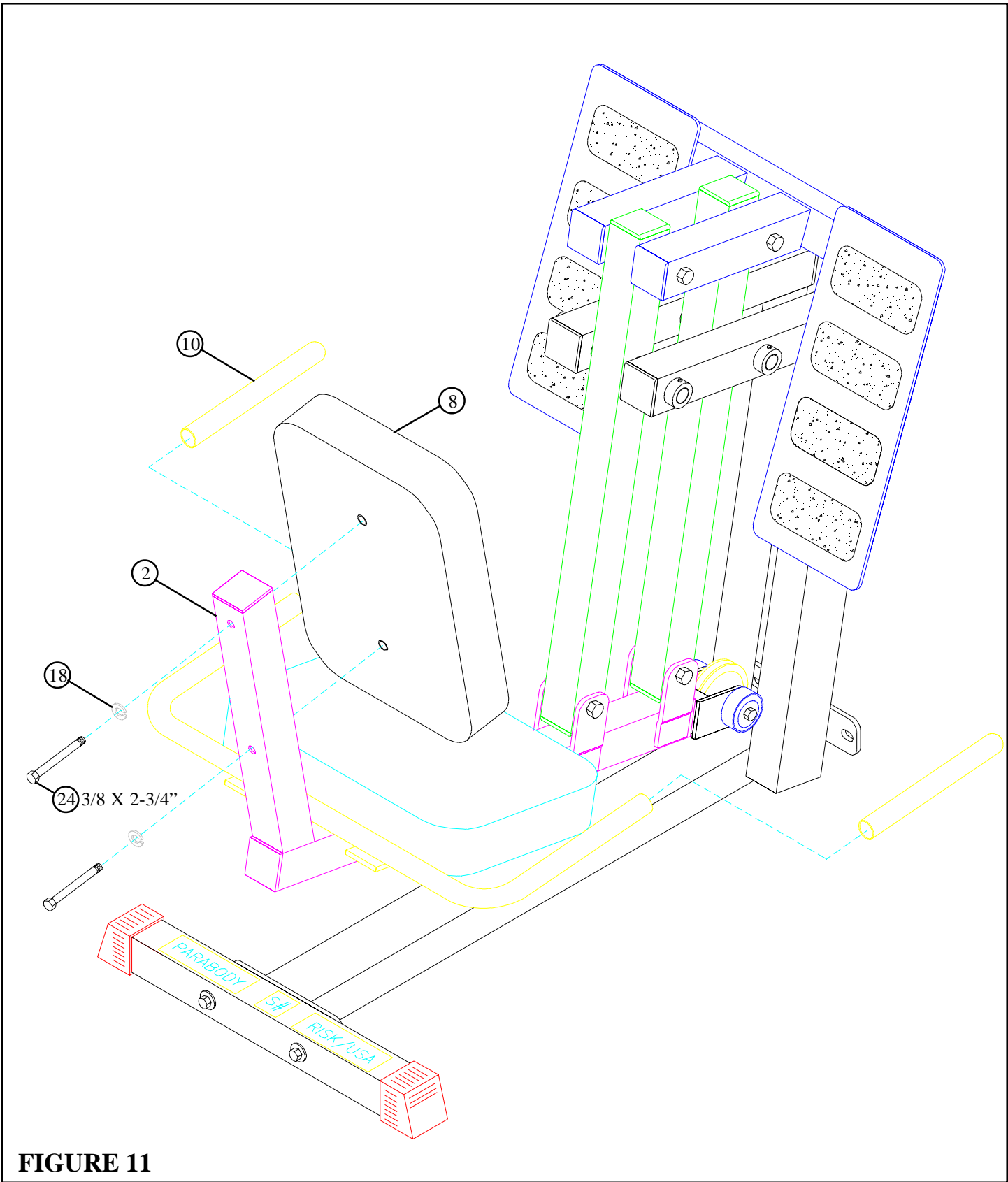


**FIGURE 10**

**STEP 10:**

- **SECURELY** assemble the SEAT PAD (8) to the HANDLE (6) and the SEAT FRAME (2) using two 3/8 X 1-1/2" BOLTS (23), two 3/8" LOCK WASHERS (18), and two 3/8" FLAT WASHERS (17). See FIGURE 10.

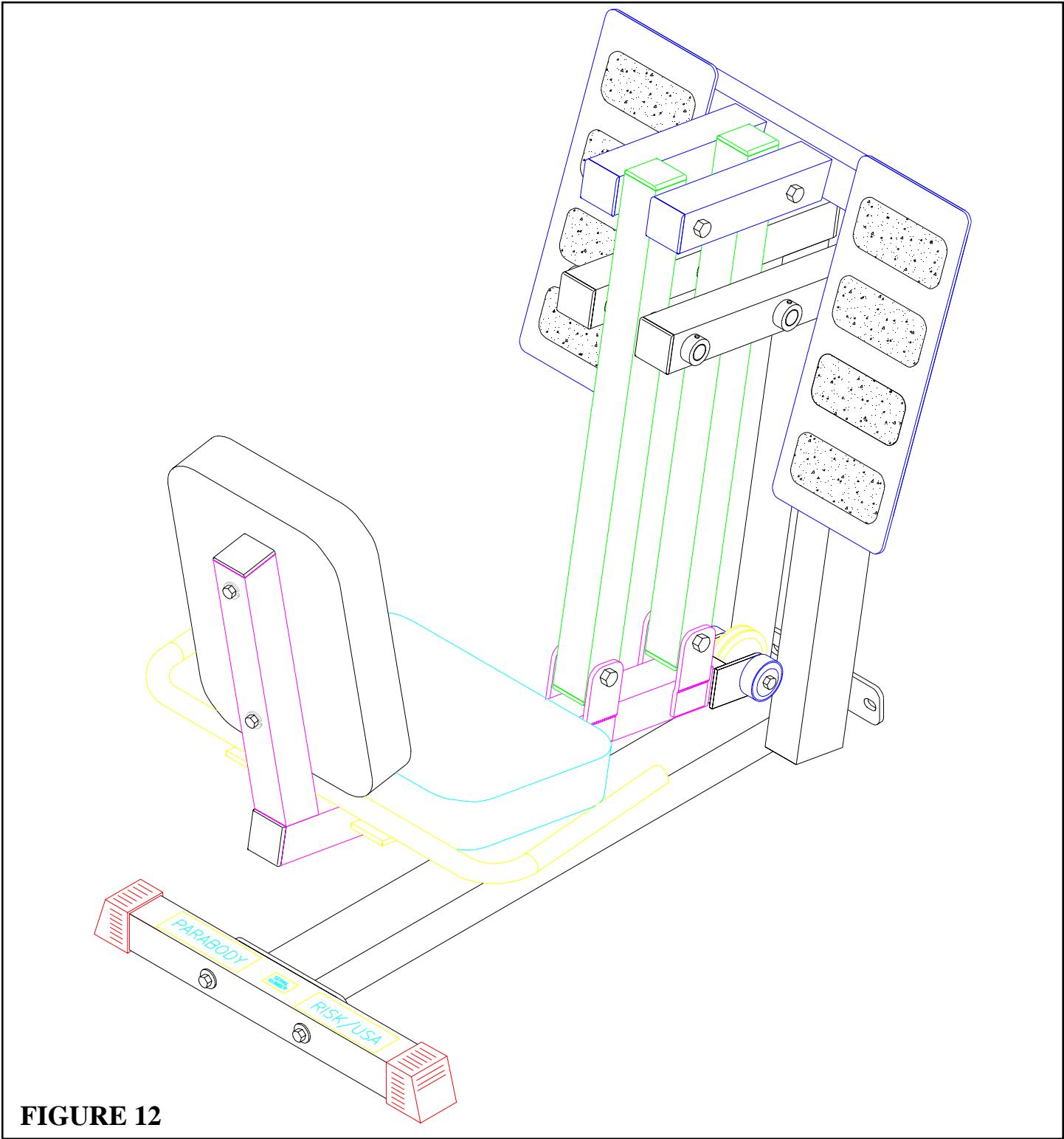




**FIGURE 11**

**STEP 11:**

- **SECURELY** assemble the SEAT PAD (8) to the SEAT FRAME (2) using two 3/8 X 2-3/4" BOLTS (24) and two 3/8" LOCK WASHERS (18) as shown in FIGURE 11.
- Slide two 1 X 8" GRIPS (10) over each HANDLE (6) as shown in FIGURE 11.



**FIGURE 12**

**STEP 12:**

- To adjust the SEAT, sit in the LEG PRESS, gently press against the FOOT PLATE and pull back on the SPRING PIN.
- Refer to the LEG PRESS ADAPTOR assembly instructions to attach the 832102 LEG PRESS to the home gym.

**Thank you for purchasing the Parabody 832102 LEG PRESS. If unsure of proper use of equipment, call your local Parabody distributor or call the Parabody customer service department at (800) 328-9714.**

